

FRITSCH

COMPLETE AND FLEXIBLE SMT SOLUTIONS



Pick & Place machines placeALL®



Innovation and quality made in Germany

Contents

placeALL®520	4
placeALL®620	6
placeALL®620L.....	8
placeALL®610XL.....	10
Axis drive and control	12
Centering modes	13
User friendly software	14
Simple program developement.....	15
Advanced working assistance	16
Software modules.....	17
Feeder systems	21
Conveyor systems.....	26
Dispensing systems.....	27
Applications.....	28
Accessories.....	30
Other machines	32
Special solutions	33
References	34
Notes.....	35

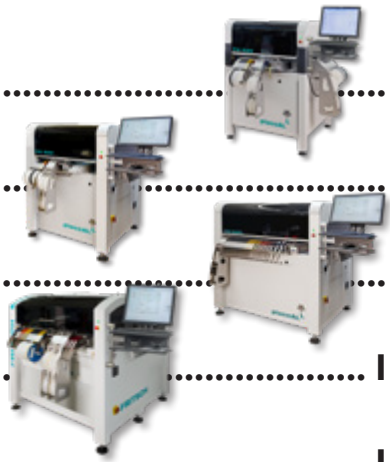

placeALL®520



The **placeALL®520** is the smallest fully automatic system from FRITSCH. The modular structure and a multitude of options make it the ideal machine for the production of prototypes and small series. Due to the wide range of components from chips up to size 0201, FP components and BGAs up to a pitch of 0.4 mm and max. 70 x 70 mm outside dimensions can even be the most complex projects can be manufactured flexibly.

Up to 200 possible feed positions and intelligent software reduce the changeover times, which affect productivity, especially with small lot sizes. The freely configurable assembly room can be used both as a pure circuit board area and for feeding components from the tray, belt section and bulk material. The integration into a line, the processing of flexible circuit carriers or the paste application by means of a dispensing valve can optionally be retrofitted.



Overview

Examples for configuration placeALL®520

Feeder slots single 8 mm or 12 mm tapeFEEDER / many 8 mm blockFEEDER

Feeder slots 100 / 200

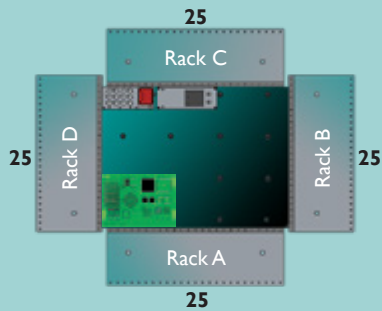

Feeder slots 50 / 100

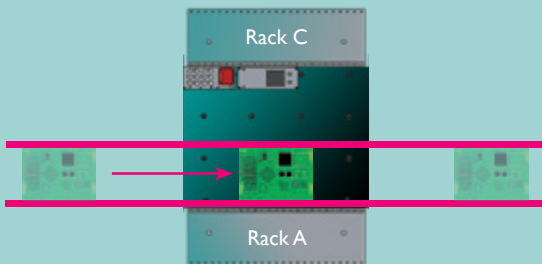

Feeder slots 75 / 150

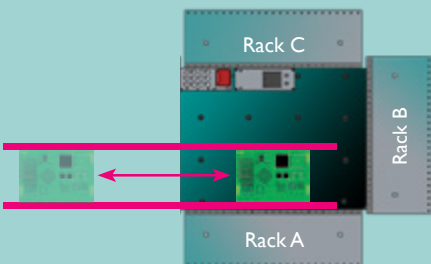

Feeder slots 75 / 150

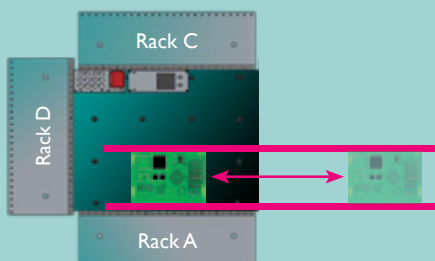

SMD fully automatic Pick & Place system with one Pick & Place head with lasercentering for 0201 chips up to 32 x 32mm, pitch 0,6 mm

placement speed up to 4000 (3200 / IPC9850) cp/h max.
100 slots - 200 feeder positions for reel 8 mm

max. board size: 520 x 430 mm

placement area adaptably configureable

Range of applications

Pick & Place and dispensing of prototypes and small series

Feeding units

Feeding of components as tape, stick, tape-strip, tray and loose components

Integration of customized feeders is possible

Features

- standalone or inline
- dividable machine frame
- max. two dispensing heads
- RCL component test up to 0201
- vacuum table for flexible circuits

placeALL®620



Like the **placeALL®520**, the **placeALL®620** has a modular structure and is used for the production of small series up to medium lots.

The range of components from chips up to type 0201, FP components and BGAs up to grid 0.3 mm and max. 70 x 70 mm outer dimensions can be processed safely. An optional 2nd placement head can even increase production by up to 40 %. 208 possible feed positions and intelligent software reduce the machine setup. The “smartLINE” combination with dispensing or other automatic placement machines not only increases the feeder capacity but above all the output of the machine.



Overview

Examples for configuration placeALL®620

Feeder slots single 8 mm or 12 mm tape FEEDER / many 8 mm block FEEDER

Feeder slots 108 / 208

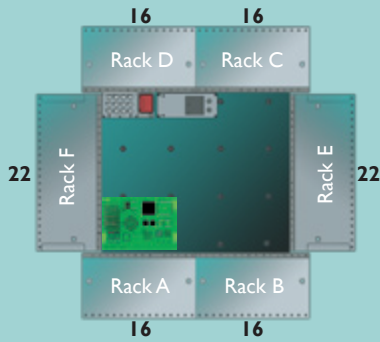

Feeder slots 64 / 124

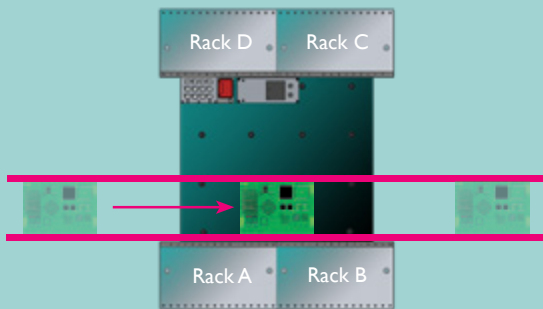

Feeder slots 86 / 166

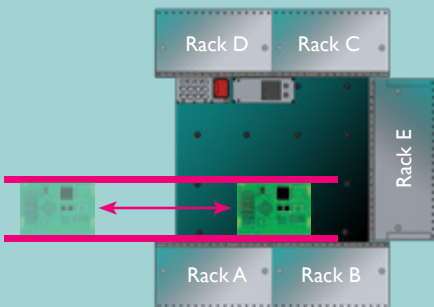

Feeder slots 86 / 166

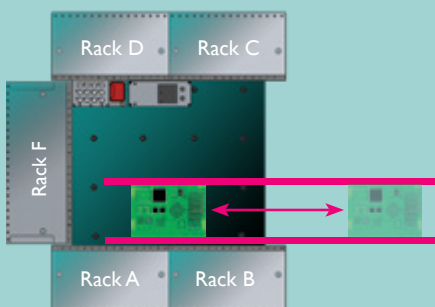

SMD fully automatic Pick & Place system with one Pick & Place head with lasercentering for 0201 chips up to 22 x 22 mm (alt. up to 32 x 32 mm) pitch 0,6 mm

placement speed up to 10500 (two heads)
6000 (4600 / IPC9850) cp/h max. 108 slots - 208 feeder positions for reel 8 mm

max. board size: 520 x 430 mm
placement area adaptably configureable

Range of applications

Pick & Place and dispensing of small series up to medium lot sizes

Feeding units

Feeding of components as tape, stick, tape-strip, tray and loose components

Integration of customized feeders is possible

Features

- standalone or inline
- dividable machine frame
- max. 2 Pick & Place heads
- max. 2 dispensing heads
- RCL component test up to 0201
- vacuum table for flexible circuits

placeALL® 620L



The **placeALL® 620L** has a wider placement space than the **placeALL® 620**. As a result, up to 284 feed positions and a maximum of 6 trays can be made available for production. The entire assembly room can also be used to assemble several small or large circuit boards (up to 920 x 430 mm). The available hardware options and software modules as well as the feeder concept are the same as for the **placeALL® 520 / 620**. This compatibility offers the easy possibility to work with several machines in parallel or to chain them.

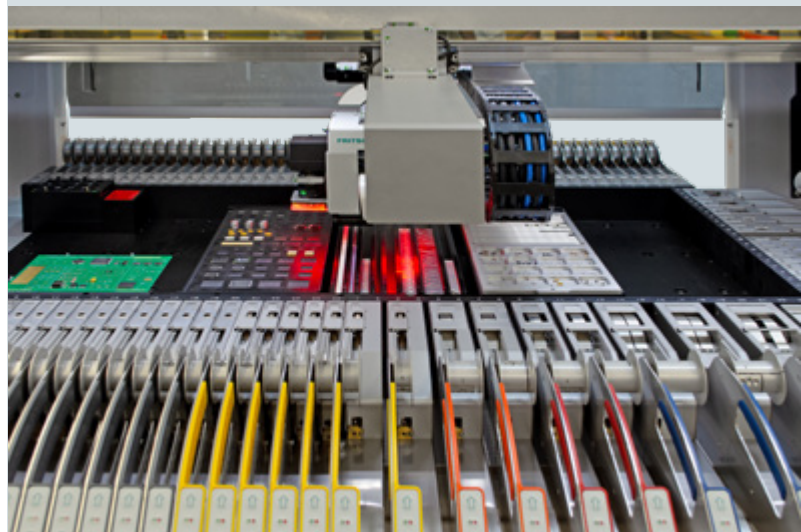

Overview

Examples for configuration placeALL®620L

Feeder slots single 8 mm or 12 mm tape FEEDER / many 8 mm block FEEDER

Feeder slots 144 / 284

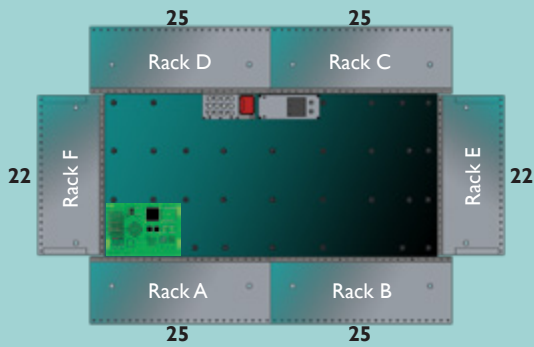

Feeder slots 100 / 200

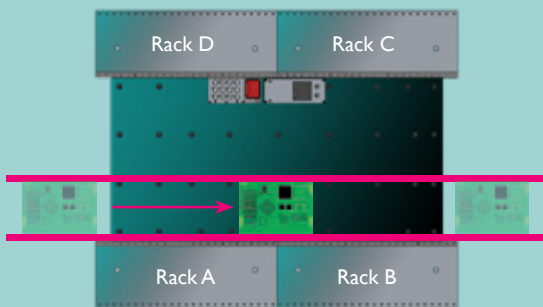

Feeder slots 122 / 242

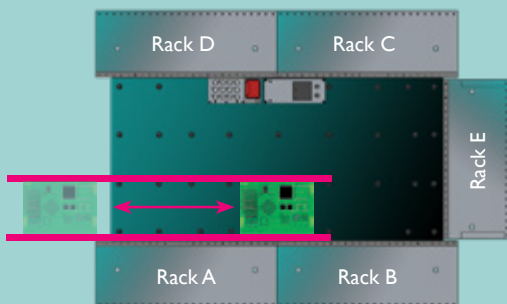

Feeder slots 122 / 242

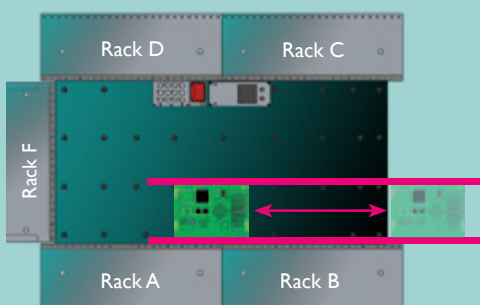

SMD fully automatic Pick & Place system with one Pick & Place head with lasercentering for 0201 chips up to 22 x 22 mm (alt. up to 32 x 32 mm) pitch 0,6 mm

placement speed up to 10500 (two heads)
6000 (4600 / IPC9850) cp/h max. 144 slots - 284 feeder positions for reel 8 mm

max. board size: 910 x 430 mm
placement area adaptably configureable

Range of applications

Pick & Place and dispensing of small series up to medium lot sizes

Feeding units

Feeding of components as tape, stick, tape-strip, tray and loose components

Integration of customized feeders is possible

Features

- standalone or inline
- dividable machine frame
- max. 2 Pick & Place heads
- max. 2 dispensing heads
- RCL component test up to 0201
- vacuum table for flexible circuits

placeALL® 610XL



The **placeALL® 610XL** offers the largest assembly table in the placeALL® series. Its dimensions also enable the largest projects to be equipped. In addition to the pure surface for printed circuit boards, it offers plenty of space for numerous trays. Up to 346 different feed positions can be provided. The available depth also allows the integration of an inline system in the front area of the machine, as well as parallel feed units from the side. Even inline, there are still 262 feed positions and space for several trays. Customized product receptacles or vacuum tables for large, flexible circuit carriers can be integrated.



Overview

Examples for configuration placeALL®610XL

Feeder slots single 8 mm or 12 mm tapeFEEDER /
many 8 mm blockFEEDER
Feeder slots 176 / 346

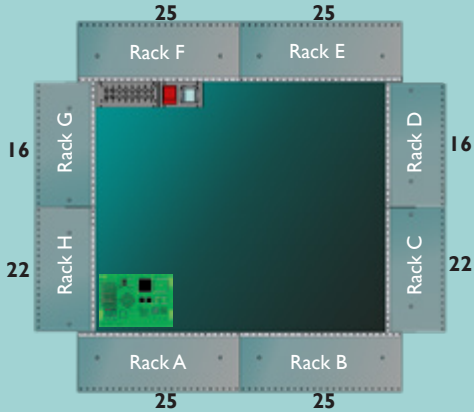

Feeder slots 132 / 262

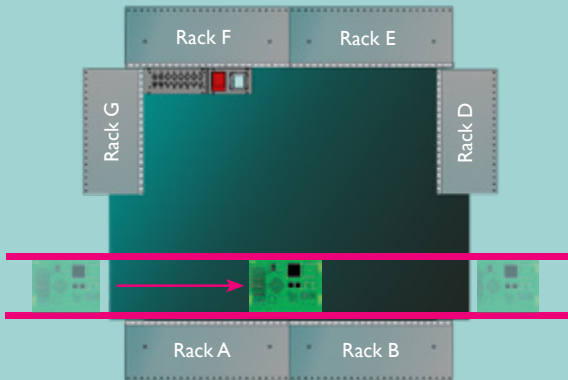

Feeder slots 154 / 304

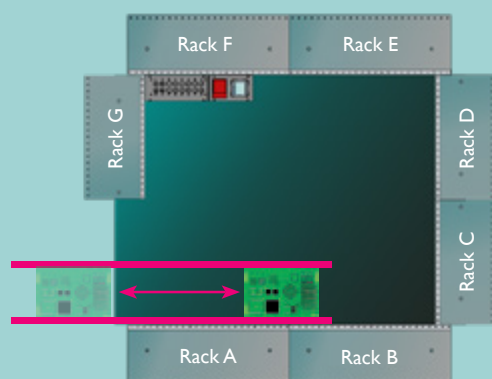

Feeder slots 154 / 304

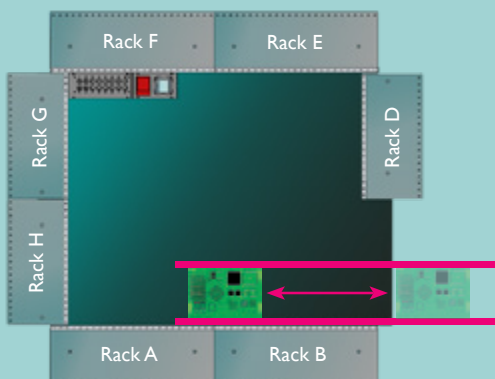

SMD fully automatic Pick & Place system with one
Pick & Place head with lasercentering for 0201 chips up
to 22 x 22 mm (alt. up to 32 x 32 mm) pitch 0,6 mm

placement speed up to 10500 (two heads)
6000 (4600 / IPC9850) cp/h

max. 176 slots - 346 feeder positions for reel 8 mm

max. board size: 910 x 760 mm

placement area adaptably configureable

Range of applications

Pick & Place and dispensing of small series up to medium
lot sizes

Feeding units

Feeding of components as tape, stick, tape-strip, tray
and loose components

Integration of customized feeders is possible

Features

- standalone or inline
- max. 2 Pick & Place heads
- max. 2 dispensing heads
- RCL component test up to 0201
- vacuum table for flexible circuits

Axis drive and control

Belt transmission

The axis of the placeAll® are constructed with belt transmission which is driven by modern DC motors in combination with a high-resolution linear measurement system. This system is mounted alongside of the axis.

The axis and assembling heads of the placeALL® range are weight-optimized constructed to minimize the accelerating force. Therefore the use of a belt drive is possible and there's no need to build in a spindle drive with shaft joint. This is an enormous advantage for cost of ownership and offers a high potential of cost reduction in service and repair according to the spindle drive.

The axis of the placeALL® combine the both advantages of these two systems in an optimal way: High dynamic of belt transmission added to the exact linear measurement system. The Encoder's high solution of only 0.5 μm at placeALL®520 and placeALL®620 is optimal completed with an axis-controller with the scanning rate of 100 μ per axis. Therefore this highly dynamic movement can be carried out exactly.

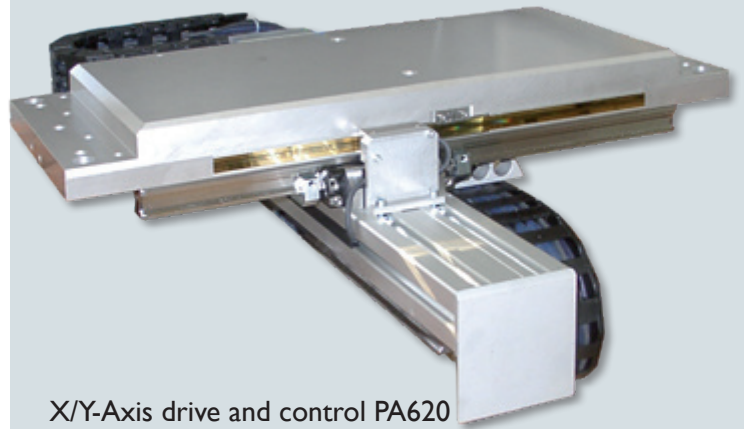

X/Y-Axis drive and control PA620

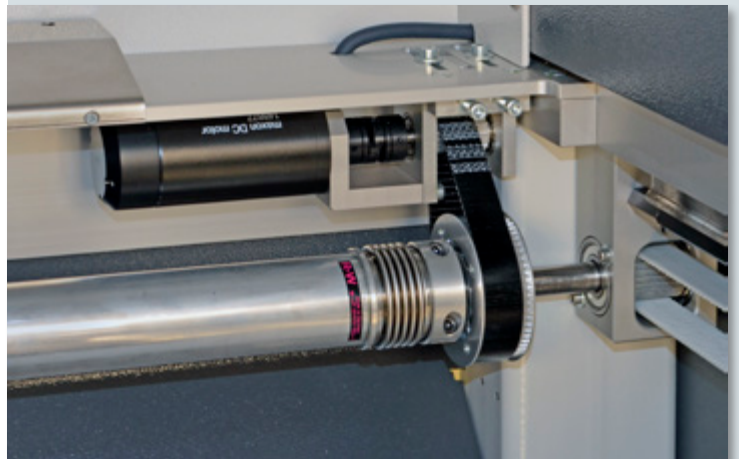

Centering systems

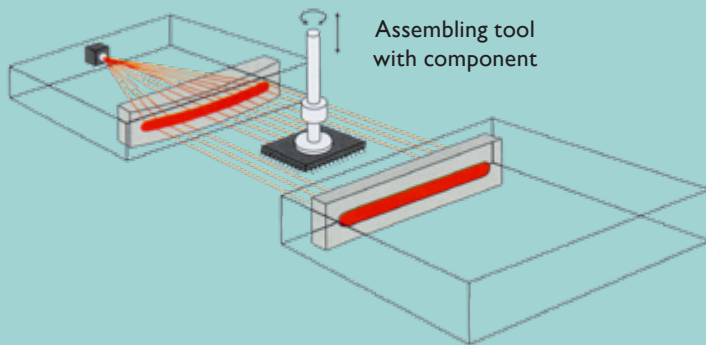

Laser centering

The laser centering is directly installed on the assembly head. The component which has to be centered is while rotating measured by the laser centering. Its shadow on the opposite side is analysed and a contactless fast centering happens. The component capability ranges from 0201 chips up to components with dimensions of 32 x 32 mm and Fine Pitch to 0.6 mm. BGAs can be centered in this way, too.

The laser centering is also a method to determine the component dimensions like length, width and height.

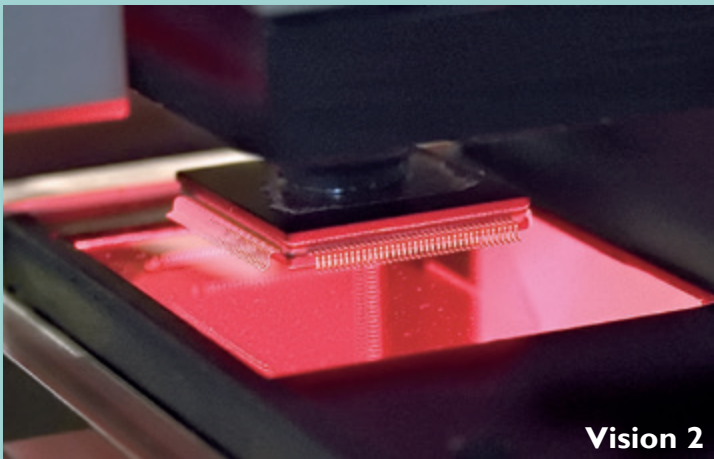

Bottom-Vision

The bottom vision is an image recognition which measures and analyses the components what are to large for the centering at the head.

The software for image recognition determines the exact assembling position and tests the BGAs of complete balls respectively that the FPs' wires aren't deformed. These components can be selected before processing. Used are components up to 0201, μ BGAs, 0.3 mm Fine-Pitch or special components like for example connectors.

User friendly software

Usability and programming

The clearly laid out software guides the user step by step to his goal. To setup a new project or alter an existing one, the parameters can be simply chosen with a mouse click. There is also a detailed help menu for each function.

The smartASSISTANT monitors all user activities, gives hints and tips and shows every error source in plain text, so it is generally not necessary to consult the user manual.

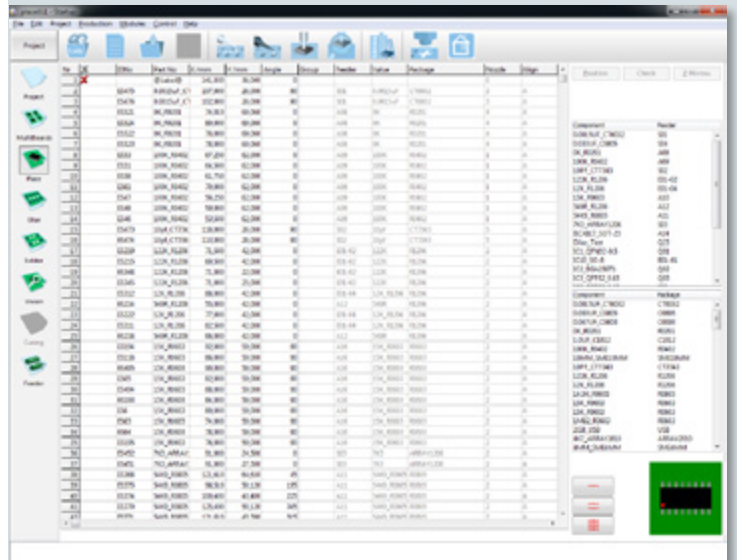

Component library

The component library contains over 450 component models. This represents one of the biggest libraries on the market today. All content items can be edited or new ones can quickly be created.

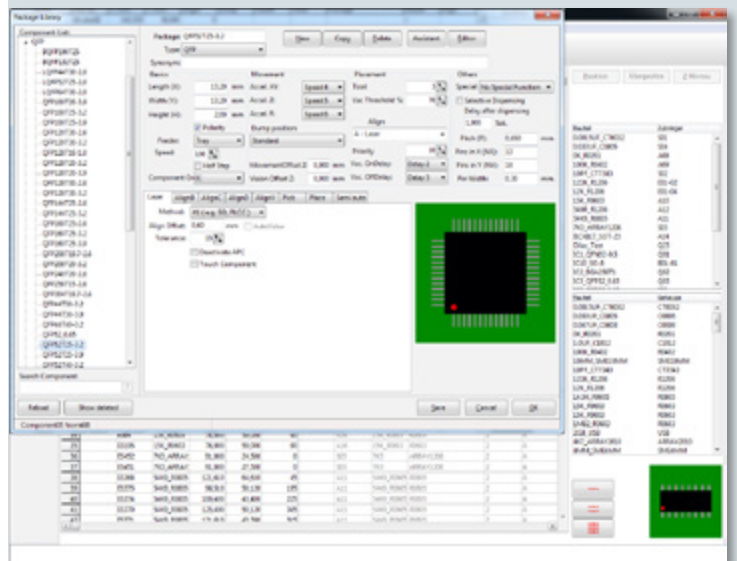

Component Editor

If components, which are not part of the default library, need to be placed, a graphical editor is used to create a new component body in just a few steps.

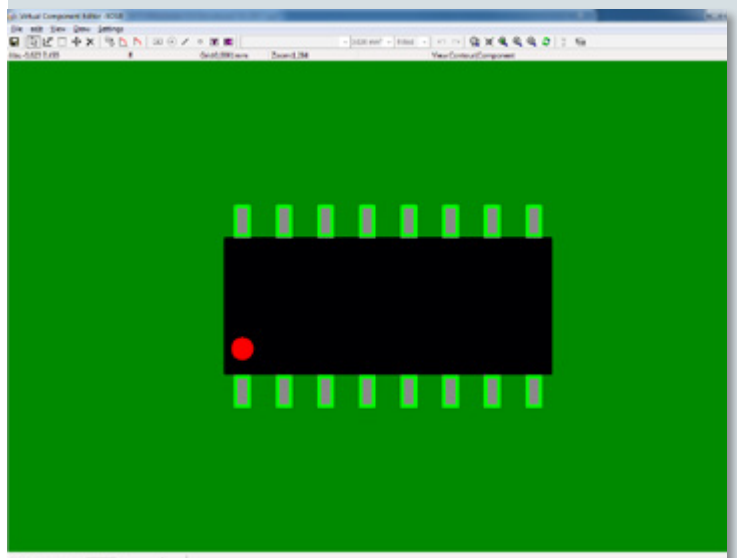

Simple project development

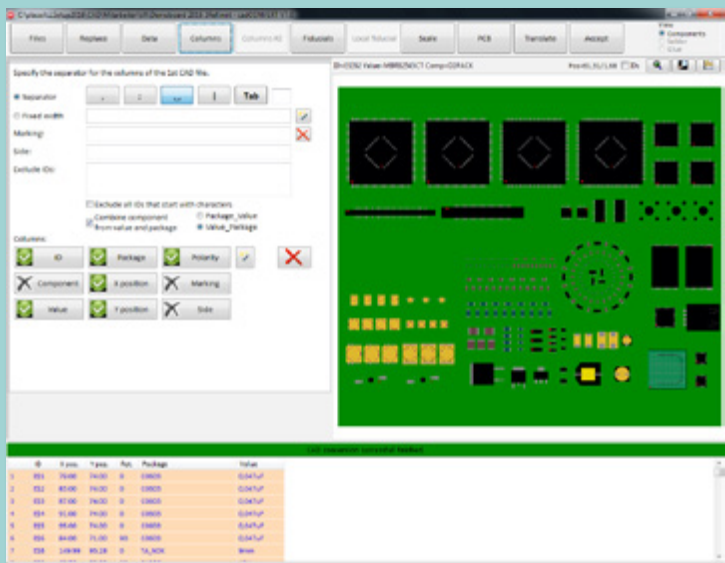

CAD data converter

CAD data from any CAD system can be interfaced easily to the projects using a format editor. The conversion process is very fast and can be done offline on a separate PC. During this process the Pick&Place machine can continue to be used for its main task of placing components.

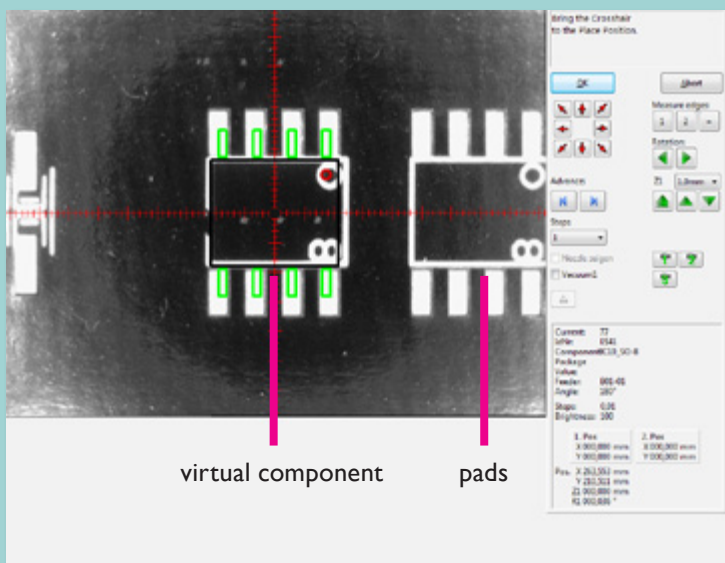

Teach In

To create a project, the user drives the head to the particular position; a virtual component is shown as an overlay in the camera window. The virtual component can now be adjusted exactly and brought into the right position. After that, its position is logged into the Pick&Place project file.

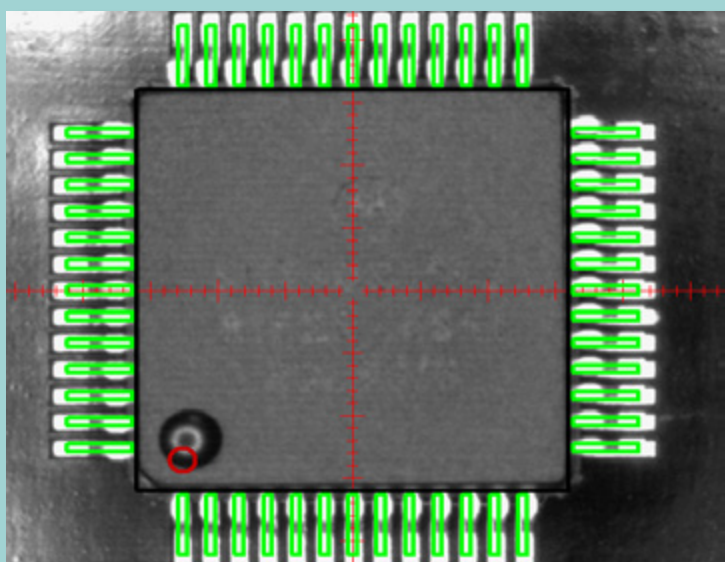

Virtual Inspection

After acquiring the CAD data the virtual inspection can be used to simulate the Pick&Place process. The camera moves across the current circuit board. At each placing position the corresponding component is blended in virtually. The position and polarity of the component can be checked and corrected if necessary. In this way error-free prototypes can be produced in a very short time.

Advanced working assistance

Monitoring the placement process

To inform the user of the current status of the Pick & Place process, the circuit board is shown on the monitor. It displays virtual components one-to-one with the real assembly.

Automatic setup control

The automatic setup control shows the result before the real assembly process starts.

The image of a PCB can be used as model. Therefore it is possible to control fast and easy the result of assembling.

Components are single or grouped deactivated or deleted. The editor possibilities like moving or rotating complete the automatic setup control to a very useful tool. While the Pick & Place process the virtual plan is displayed to control the real advancement of assembling.

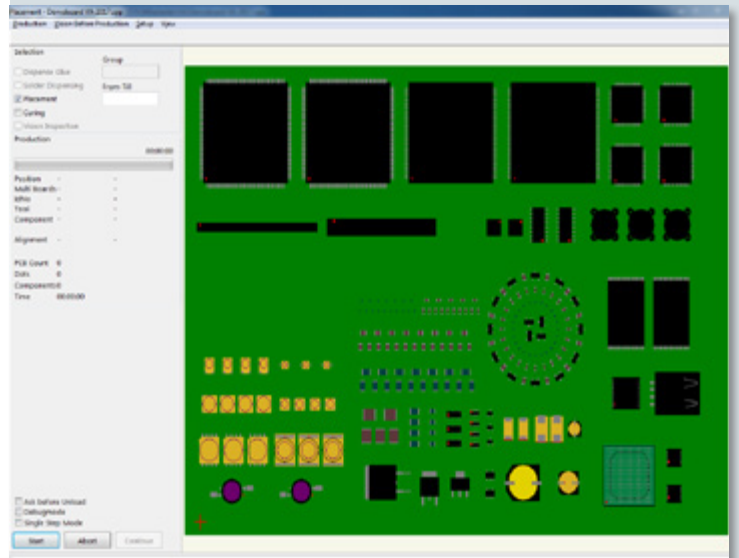

User management

The user administration makes it possible to assign different rights to different users. The person who is able to edit programs or update component libraries can be defined, and other users can be locked out of these functions. These rights can be easily edited by clicking on the different production steps in the software.

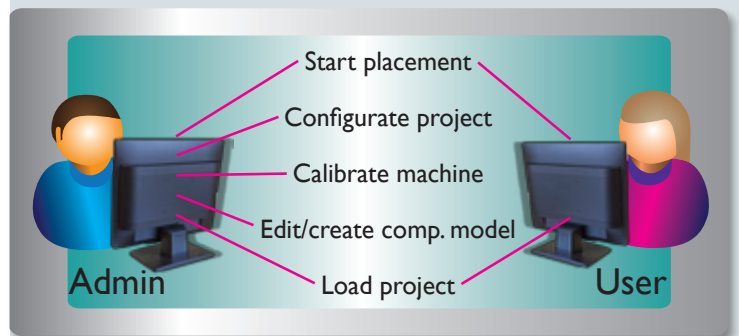

Remote Support

Remote access to your machine by our technicians is possible using the service kit, after having your approval. This connects us directly into your placeALL® and the installed software to rapidly provide an overview of the machine's status if any questions occur.



Software modules

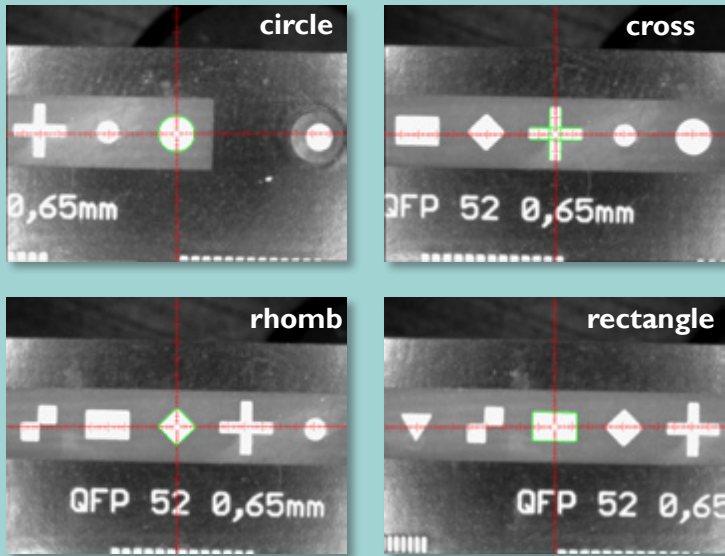

Software modules

All described software modules can be refitted to your software on demand.

Autom. fiducial recognition

To set up an assembly, reference marks such as crosses, circles, rhombi etc. can be read in automatically. The camera captures the exact position of the circuit board before the assembly begins.

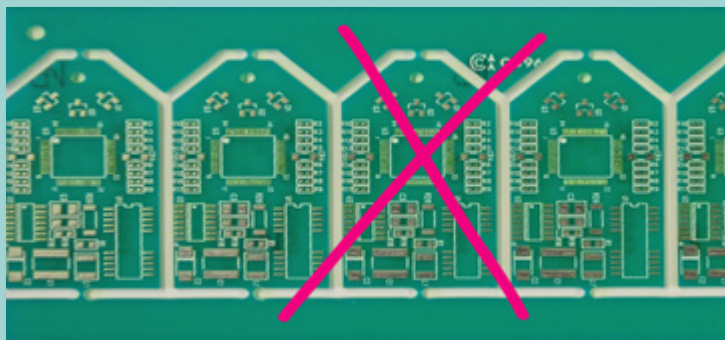

Badmark recognition

The recognition is searching automatically for a mark on a defined position whether the PCB should be signed as bad and shouldn't be assembled. The sign is identified in cause of its brightness. Light or dark marks (made with labels, pens or ink pints) can be recognized.



Offline programming

With this CAD conversion, assembly and dispense data as well as the whole libraries can be edited at a separate workstation. The processed data can be transmitted to the Pick & Place machine afterwards.

Software modules

PAsmartBULK

This module offers an automatic search for bulk goods components and the integrated component turning station even fully automatically turns parts that are the wrong way up.

The automatic component search alleviates and accelerates the production of the smallest series and prototypes considerably. The software automatically scans with the head camera for the required components prior to each assembly. In doing so, it even takes into consideration the component size in case a wrong component happens to be in the tray.

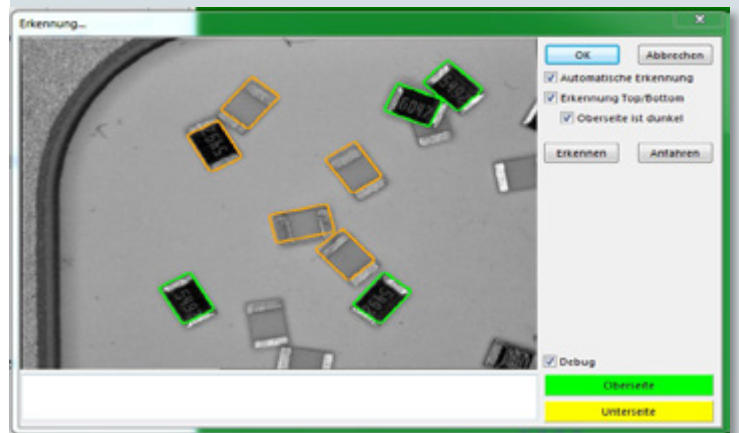

PALoose Components

The placeALL® range offers by standard a procedure for manual picking of single components to create the assembling of loose components effective and safe. The machine isn't only able to pick single components from a feeder. It features also the possibility to mark any components before starting the assembling. This enables the user to begin an automatic assembling after designing.

The optional smartBULK feature recognizes automatically the loose components in the container. This quickens the assembling significant.

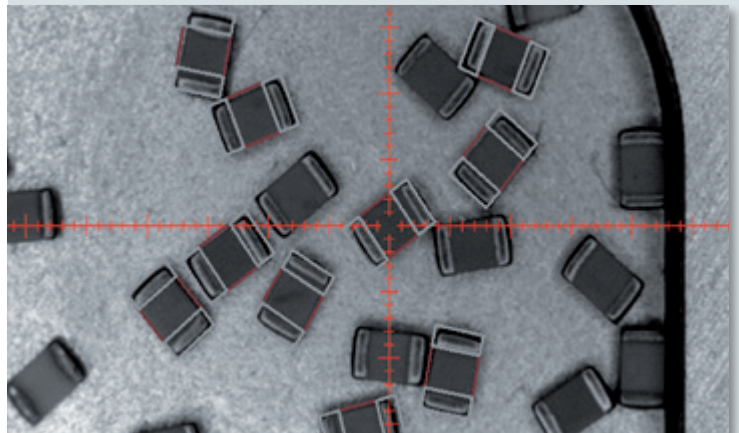

PA barcode label

With this module it is possible to print out your own barcodes for the administration of components. Together with the barcode module, quick, simple and secure set up is possible. The barcodes to be printed out can be individually adjusted via a designer.



Software modules

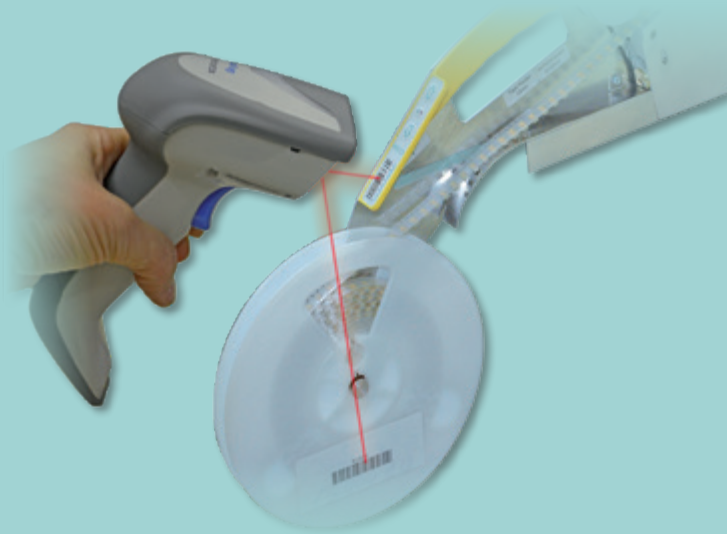

PABarcode

All smartFEEDERs can be set up using a wireless barcode reader. Together with the warehousing module you can read out the current stock. By using the reader for a setup, it is ensured that the correct component is set up on the correct feeder.

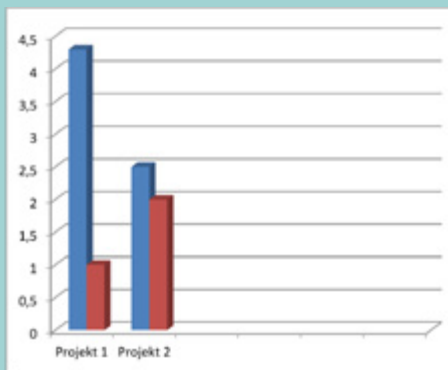

PAStatistics

To calculate an order, all available data such as assembly time per circuit board is documented and analyzed by this module.

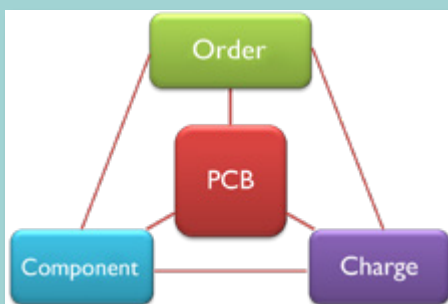

PATrace

This module documents which component from which lot has been used on which circuit board and with which order. This enables historical production runs to be interrogated, in case of a recall enquiry.

PAStorage

This module manages all SMD parts, circuit boards and other components used in production (like heat sinks or other standard parts) that you have in stock. The assembled components are debited from the stock automatically as they are used. The user is informed by settable minimum stock levels, whether a stock item has to be reordered.

PAStorage distinguishes between the whole warehouse and the parts currently stored on the machine.

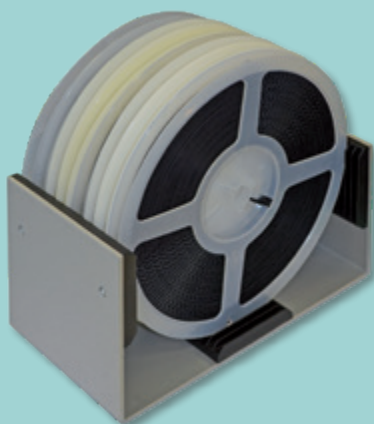

Software modules

PANetState

All machine messages are transferred to a separate PC on the network and displayed there. The user is informed i.e. if production is finished and can initiate further steps.



PALevel

For assembling of MID interconnect device the module „Z-Level“ can be integrated. This module enables the placing of components on different levels - on higher and deeper levels. So the module is useful for placing components on interconnect device like for example Embedded Components in PCBs.

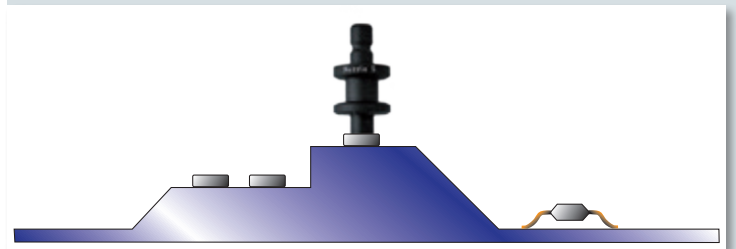

PA-LEDpairing

The optional software-module PA-LEDpairing has been developed to combine LED to resistor. So the manual assignment isn't longer necessary and errors can be avoided.

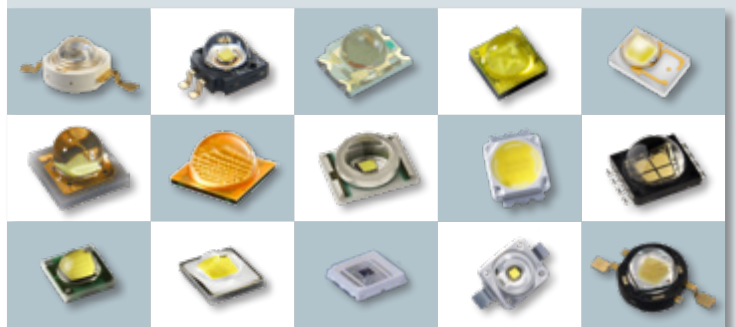

Feeder systems



The placeALL® range of fully automatic machines offers the right feeder for every SMD model.

The feeder system includes feeders for rolls, sticks, trays and for loose components and is available for all automatic machines.

smartFEEDER

Especially in the case of smaller and medium-sized lot sizes, the feeder system has to be flexible and absolutely safe to guarantee high quality at low costs. All the information about the assembled components is stored in the smartFEEDER itself.

Automatic recognition

When plugging in a smartFEEDER, the feeder is automatically logged in to the system. In this event, not only the data of components are automatically passed on to the feeder but also the picking positions. The system log-in takes only a few milliseconds. Thereby it doesn't matter which feeder slot or to which side of the machine the smartFEEDER is plugged into.

The pick & place machine immediately knows the picking position and its feeding program is automatically adapted to the new feeder without intervention of the operator. Empty feeders can thus be replaced during the current feeding.

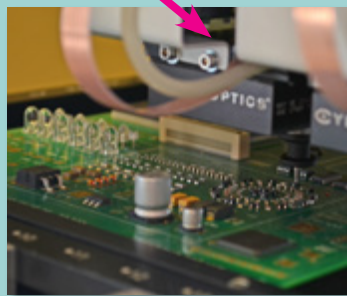
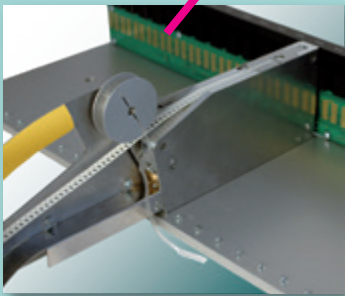
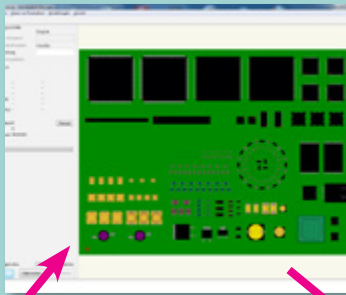

plug-in



log in



assemble

0ms

50 ms

100 ms

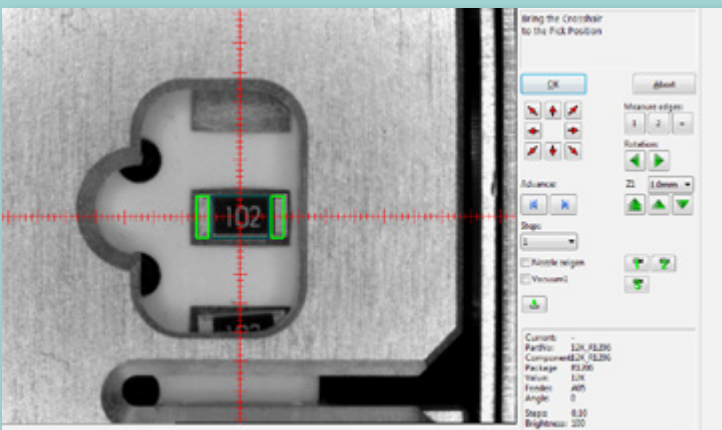

Automatic pick & place correction

The serial software module automatic pick&place correction (APC) continuously monitors the picking position from the feeders. In the event that the picking position is not correctly calibrated or the picking position of a belt changes slightly during assembly, then this module will automatically adjust the picking position and the stability of placement/assembly will be significantly increased. APC applies a statistical procedure for the correction of the picking positions. Therefore, individual outliers do not cause a faulty correction. The APC is part of the software of the fully automatic machine of the placeALL®-series.

Feeder systems

tapeFEEDER

All tapeFEEDER are smartFEEDER. They have an easily accessible control panel for the manual infeed and outfeed, a status indication with 2 LEDs as well as the series number with bar code, through which the feeder can also be equipped with a bar code scanner. The feeders can pick up rolls up to 8" by default. With extensions 13" rolls can be handled.

Technical details:

- 8 mm - 72 mm tape width
- for blister- and paper tapes
- direction change tapes $\varnothing=64\text{mm}$
- mikroprozessor controlled
- high speed communication
- redundant plug

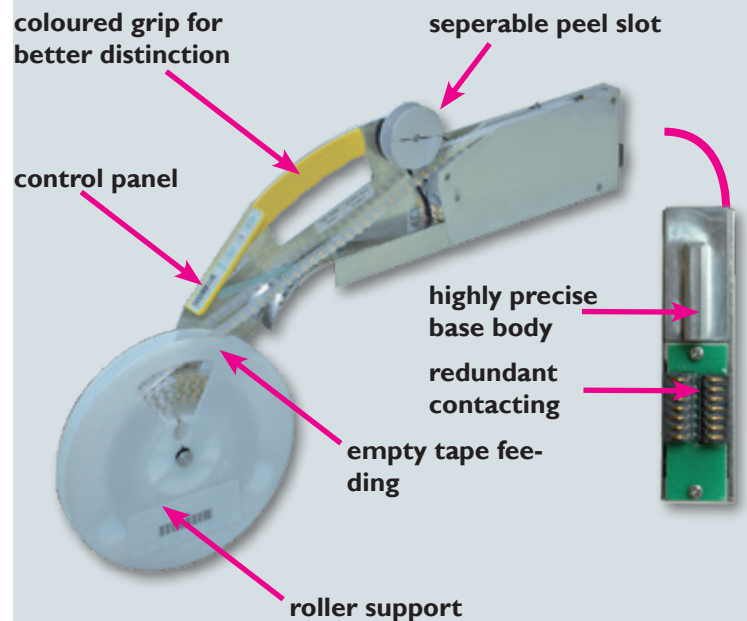

threading

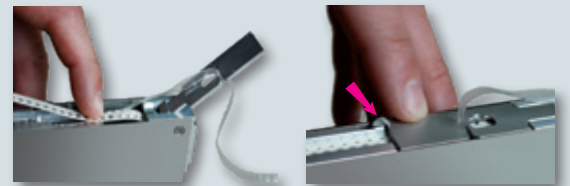

blockFEEDER

The use of blockFEEDER can facilitate a space saving set-up of the components to, for example, implement a standard set-up, during which standard components remain always mounted on the machine. Only a few project specific components must be retrofitted.

- Processes 10 x 8 mm tapes with \varnothing 180 mm optional 5 x \varnothing 180 mm and 5 x 330 mm
- max. thickness of the tape 1.1 mm; max. height of the tape 1.6 mm
- Dimension from the tape to the border of the tape min. 1 mm

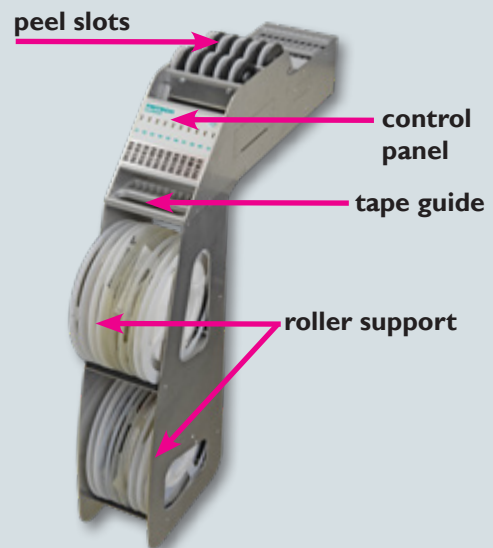

vibrations tubeFEEDER

Both the amplitude as well as the frequency can be adjusted on the stick feeder. This allows an optimal adjustment of the infeed to the set-up components. The vibration starts automatically by removing the components and stops automatically after a set length of time. This ensures that sufficient components are always available.



Feeder systems

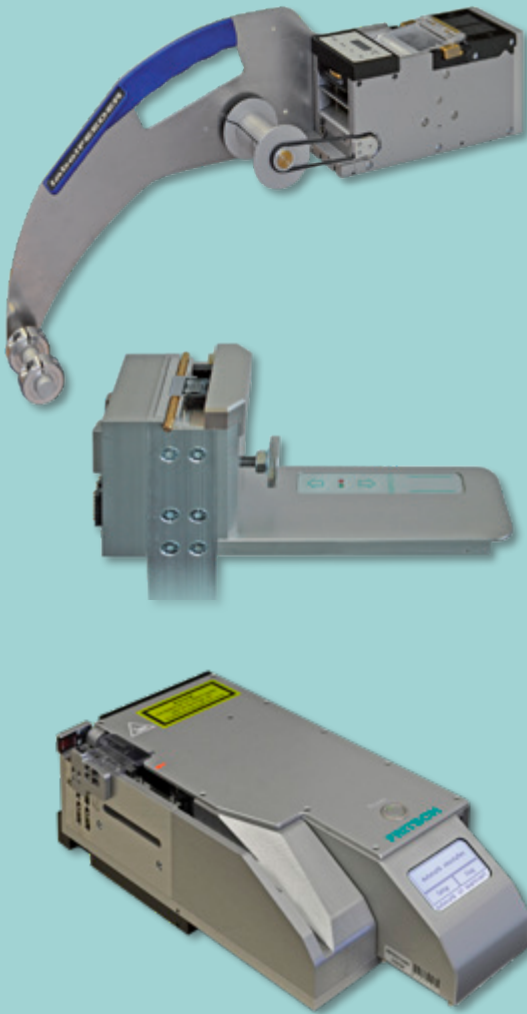

labelFEEDER

The FRITSCH labelFEEDER allows an exact label transport to the picking position of the pick&place machine. A fast setup is guaranteed by the well-arranged four-button control panel and the wide range of label- and tape sizes fitting to the feeder. Together with the compact dimensions of the unit a highly efficient labeling solution was created.

domeFEEDER

For the production of keypads feeder for the support of domes are available. The feeder are useable for all standardized domes. We can also implement customized solutions.

ledFEEDER

There are feeders for assembling THT LEDS available for all machines of the placeALL® series. These feeders feed the LEDs from standard reels, cut the wires and place the LEDs in the right position for assembly. The length of the wires can be adjusted with corresponding adapters to any size.

FEEDERtype	Order number	Slots	Tape width	Tape depth ^①	Rack-Position	Notes	
tapeFEEDER	908.121.008	1	8 mm	6 mm	all	half step for 0402/0201	
tapeFEEDER	908.120.008	1	8 mm	6 mm	all		
tapeFEEDER	908.120.012	1	12 mm	6 mm	all		
tapeFEEDER	908.120.013	2	12mm	13 mm	all		
tapeFEEDER	908.120.016	2	16 mm	13 mm	all		
tapeFEEDER	908.120.024	2	24 mm	13 mm	all		
tapeFEEDER	908.120.032	3	32 mm	13 mm	all		
tapeFEEDER	908.120.044	3	44 mm	13 mm	all		
tapeFEEDER	908.120.056	4	56 mm	13 mm	all		
tapeFEEDER	908.120.072	4	72 mm	13 mm	all		
blockFEEDER	908.160.008	5	8 mm	3 mm	all		for 10×8 mm-tape
tubeFEEDER	908.121.002	5	-	-	all		for 10×SO08
trayFEEDER	908.170.410	13	-	-	machine-specific		for 8 x JEDEC Tray

① Please take note of the bending radius.

Feeder systems

trayFEEDER

- up to 8 Jedec-Trays
- automatic supply of the right component while assembling
- integration in the operating interface
- retrofit at existing machines
- integrated controller of axis for gentle motion of the high-value components

Tray holder

Multiple tray holder per one JEDEC tray can be used inside the placement area. Thus the placement area of the Pick & Place machine can be adapted easily to different projects and tasks.

Tray for loose components

The loose-component feeder for the placeALL® includes 36 pickup positions. Every tray has a clear cover, to keep the components shield and clean from dust.

IC FEEDER

25 different ICs can be equipped on the IC feeder. Therefore it has inserts with three different widths for different applicable components. These inserts can be adjusted on custom made projects.

Universal tapestripFEEDER

The universal tapestripFEEDER for tape strips or whole rolls can be mounted in addition to our smartFEEDER around the machines. Therefore the user has more inner space for PCBs or trays.

Tape-strip feeder

When assembling prototype runs, tape-strips are often used. With this feeder, up to eleven 8 mm strips (or fewer, but wider strips) can be fed simultaneously.

Holder for high component tapes

The Universal-Tape-Strip-Holder is suitable for component tapes up to 27 mm height. Built for the use of tapes with a width from 8 to 56 mm.

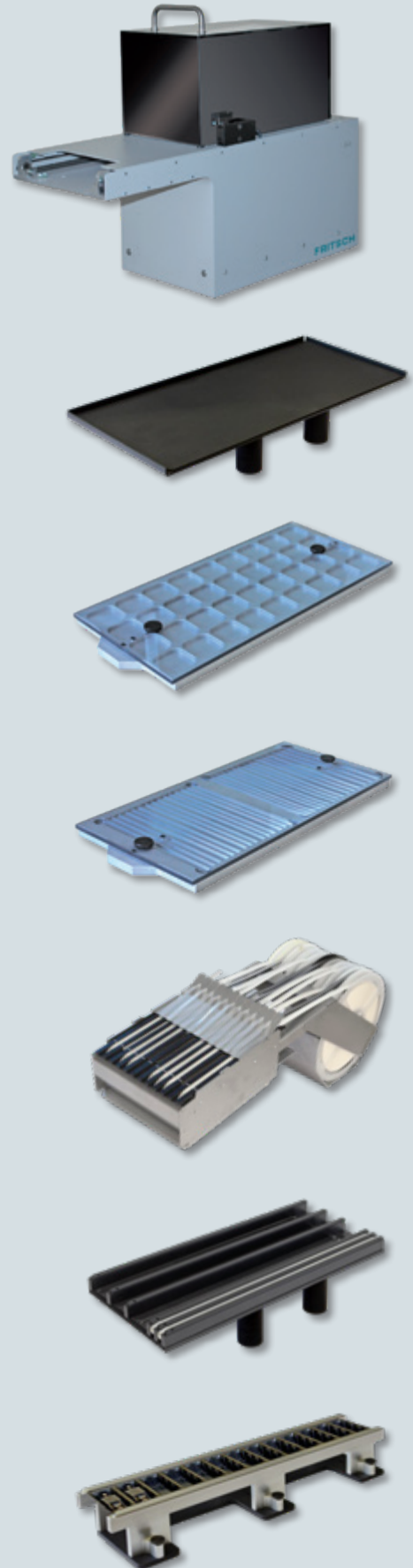

All these feeders can be placed in the assembling area by magnetic bases.

Feeder systems

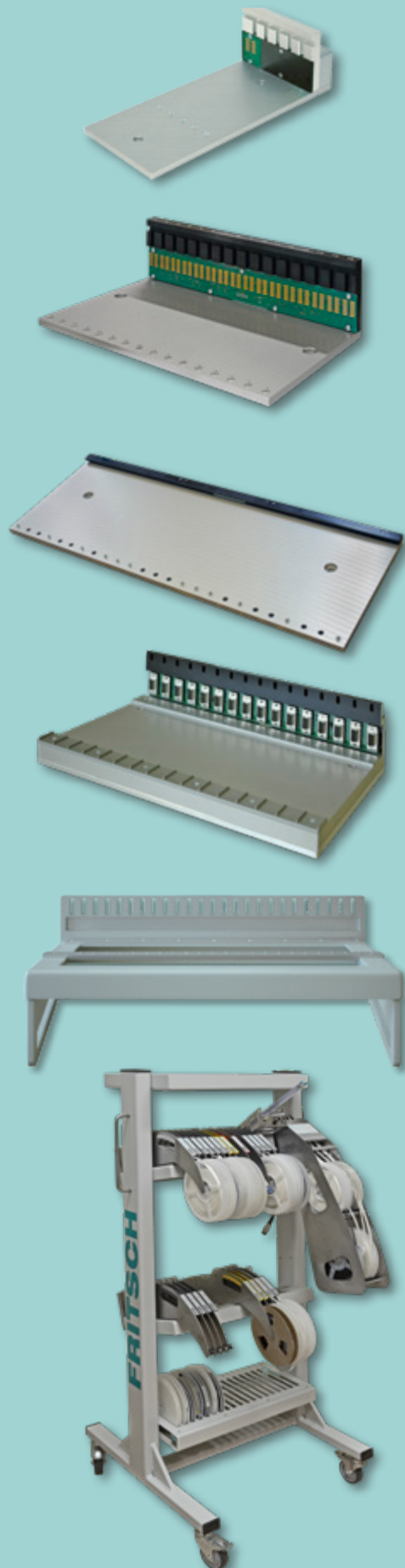

Feeder set-up stations

An external feeder set-up station enables a set-up of feeders irrespective of the machine. Thereby the set-up of a new project can be carried out at the same time as the current project is still being assembled.

Feeder racks

Feeder racks are required to use tape or tube feeders on the machine. Each rack ensures the communication to the individual feeders. Depending on the type of machine, different feeder racks can be mounted.

Rack for universal tapestripFEEDER

This rack guarantees the safe intake of universal tapestripFEEDER.

Feeder adapter

The feeder adapter allows the use of belt and bar feeders using a sub-D connection on present machines. The adapter allows the set-up of the feeders in the software and thereby emulates the additional functions on present machines.

Table feeder storage

Portable or at the working place mountable feeder compartments enable the solid and vertical storage of feeder which are not in use at the machine.

Feeder storage rack

The feeder trolley makes it possible to safely store all feeder units that are not required for the current assembly process near to the placement machine. Whilst the machine is producing, the operator can already get the feeders needed for the next project on the feeder trolley.

The feeder trolley has the following racks:

- 2 x racks with 25 slots for feeders
- 1 x rack for small parts

Conveyorsysteme

Fast and easy

The standstill and changeover times must be reduced, especially for small series. The different conveyor systems have been optimized precisely for this. Both the setting of the PCB width and the positioning of support pins below the circuit board are done without tools. Depending on the application and local conditions, the optimal conveyor for PCB transport can be selected:

- motorized width adjustment
- Flat belt
- 3 zone conveyor
- one-sided batch conveyor from left or right

Customization

By request the conveyor can be equipped with a customized intake for workholding fixture. This enables to handle even heavy or customized workholding fixture in the placeALL®.

Stressless motion

To bring sensitive PCBs such as ceramic substrates or partial assembled PCBs safely to the placement position, the PCBs are slowly moved through a ramp of deceleration to the stopper and so the mechanical load is reduced to a minimum. All conveyors are fully programmable. The rate of feed, ramps and waiting times can be adapted to the application.

SMEMA Interface

Each conveyor has the standard SMEMA interface. Thus, machines can easily be integrated into any production lines or even combined with a loader and unloader to automate partial the pick & place process.

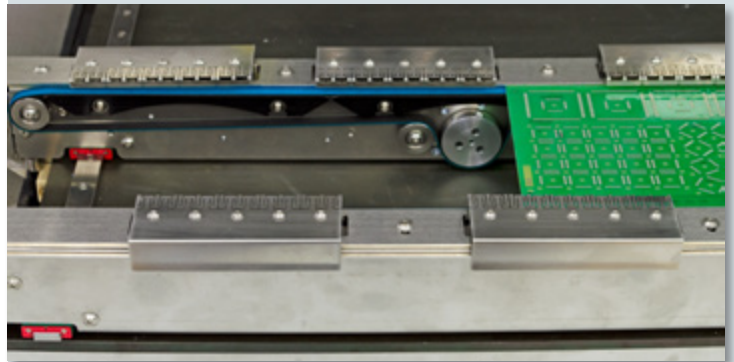

Standalone

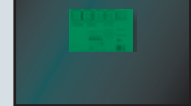

Batch-System



Inline-System



Dispensing systems

Dispensing valves	PA520	PA620/L	PA610XL
Time-pressure	✓	✓	✓
Precision	✓	✓	✓
Jet-Dispensing-System		✓	✓

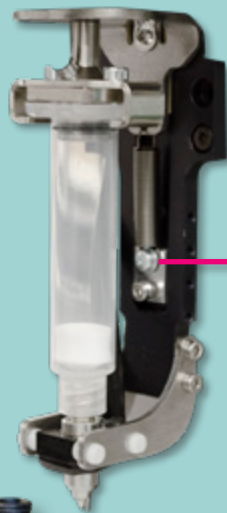

Dispensing module

While the production of prototypes and small series it is an advantage to bring glue or solder paste with the help of a machine on the PCBs and than to assemble it. Several dispensing systems are available and with the double dispenser module it is possible to handle two various fluids.

Time-pressure dispenser valve

The simple means of attaching the valve makes it particularly robust and low-maintenance. The adjustable pressure affects the cartridge after a short period. The desired amount can easily be set in the software. Normally for solder paste or glue for rough structures.

Precision dispenser valve

In the case of the precision dispenser valve, additional parameters such as temperature and the fill level of the cartridge are collected. The processor control regulates these values, the pressure and the time of the dispensing impulse in order to achieve the highest repeat accuracy. This enables the safe dispensing of amounts from 0.001 to 10 mm³. By this Fine-Pitch components down to a pitch of 0.5 mm can be safely dispensed.

Jet-Dispensing-System

Jet valves from various well-known manufacturers can be defined and integrated depending on the application. The high dispensing frequency makes it possible to apply both the smallest and larger quantities with just one dispensing head.

Large components

Although the size of constructions in the electronics industry has been further minimised for many years, there are still sufficient fields of application where a miniaturisation is not possible. In order to automate the assembling of such constructions, a machine is required that excels with both component dimensions and with its flexibility.

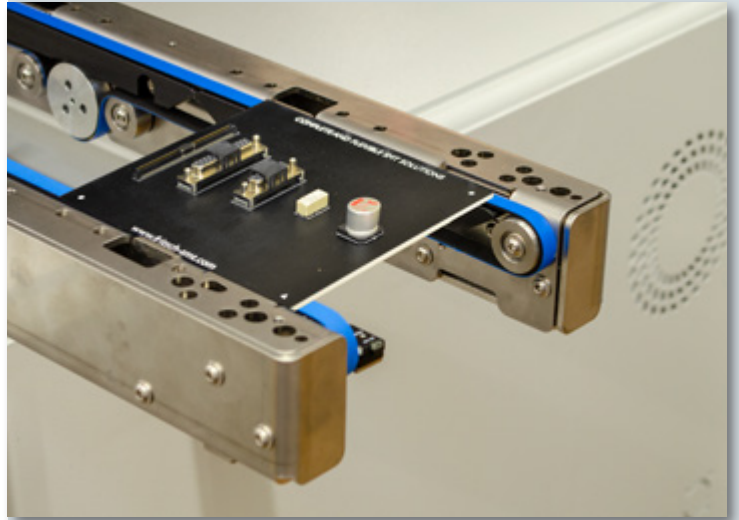

Flexible PCBs

Be it a flexboard only or a Starrflex PCB, both provide enormous potential for optimising costs or they offer a compromise between a rigid PCB and a 3D MID component. Flexible PCBs are easier to integrate into the existing mechanical environment and thus create a new way of implementing your developments. Typical applications of these boards can be found in the automotive industry or robot technology.

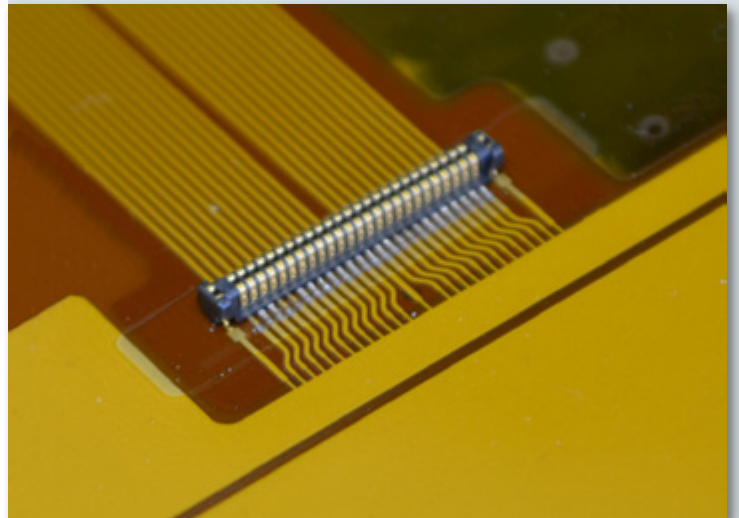

Production of membrane keyboards

The manufacturing of membrane keyboards or displays is still mainly manual production of the components. FRITSCH provides some unbeatable options for cost optimisation and acceleration of production with their pick & place machines for the assembly of domes and LEDs.

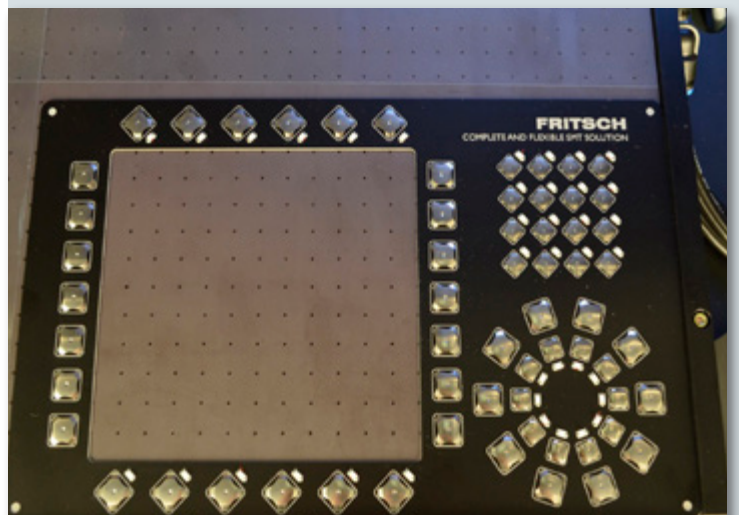

Applications

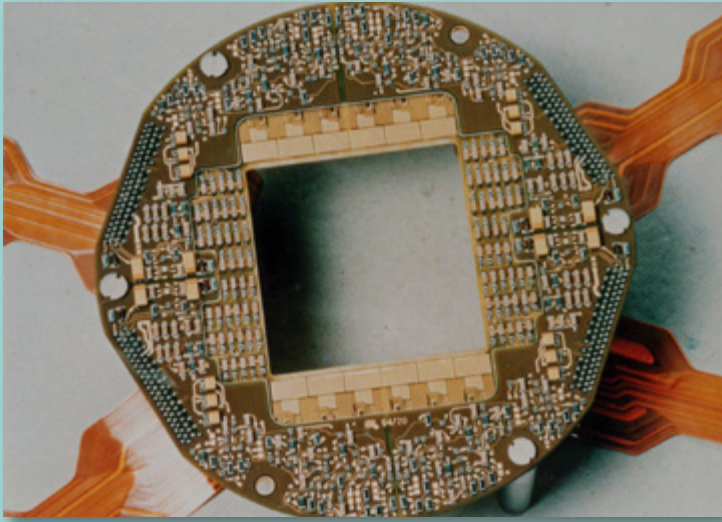

Aerospace

The electronics production in aerospace pursues entirely different goals than conventional electronics assembly. For more than 20 years now, FRITSCH has been developing special pick & place machines for this sector in close cooperation with the respective companies and institutions.

Back then, it all started with semi-automatic assembly stations with integrated component testers for measuring the component values – immediately before assembly. This was the only way the extreme demands of traceability and product quality could be ensured.

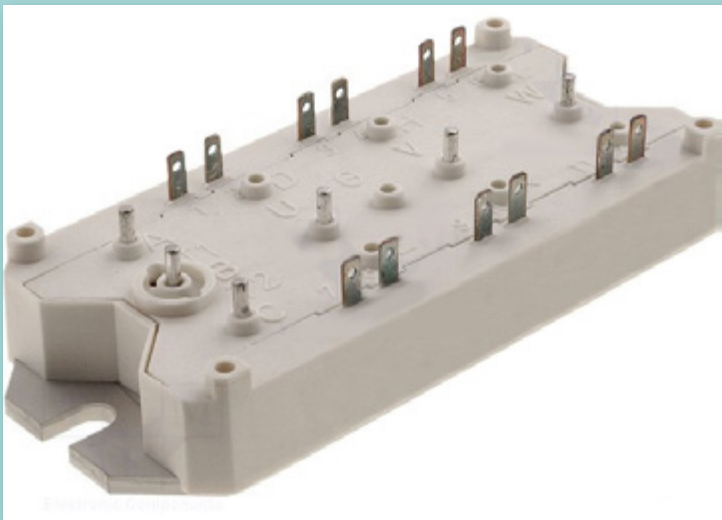

Power electronics

Electric power systems in the automobile sector, industry or many others fields of application require optimised motor electronics for their efficient functionality. When producing power electronics, other materials than for normal electronics production are used.

Thicker layers of copper for higher currents, aluminium or ceramic as carrier material require specially adapted production equipment.



Odd shape assembly

The pick & place machine has a vision system that, in a very easy way, can recognise and align any shape. This way, even irregular components such as inductors, switches or similar can be assembled in place.

Due to the component height that can be processed of up to 26 mm, the placeALL pick & place machine also enables the production of dissipators, shields or other mechanical components. Thanks to the adjustable pressure when assembling such components, mechanical alignment pins can be printed into the PCB.

PCB intake

The universal PCB quick-device allows easy fixing of single or double-sided PCBs with different shapes. Therefore are various fixed magnetic recordings.

- PCBs up to 1020 x 770 mm
- Clearance under the PCB 32 mm
- Clearance above the PCB 22 mm
- Single- and double-sided PCBs
- No tools for adjustment
- Free positioning of PCB support with a magnetic
- Components up to a height of 20 mm possible to place



Vacuum table

For assembling of flexible PCBs a vacuum table can be integrated. There are variants for a complete vacuum suction of PCBs as well as for a partial vacuum suction. The attachment of the vacuum table is possible without the use of tools. A changing from vacuum table to the conventional PCB intake happens with the help of the grips just in a few moments.



Auto-Blow-Option

To ensure the replacement of flexible PCBs, blow-off-option can be integrated. This device will be activated just before the extension of the PCB carrier and brings a minimum air film between the substrate and vacuum table for a clean separation and to ensure safe transport of the PCB.

Assembling tools

As standard, the placeALL® has six different tools per placement head, which are spring-loaded, so that smaller differences in the placement height can be compensated for. The tools can be easily dismantled for cleaning purposes.

The FRITSCH company offers a large tool portfolio for the fully automatic placement systems. Customer-specific tools are also manufactured. Please feel free asking us!



Accessory

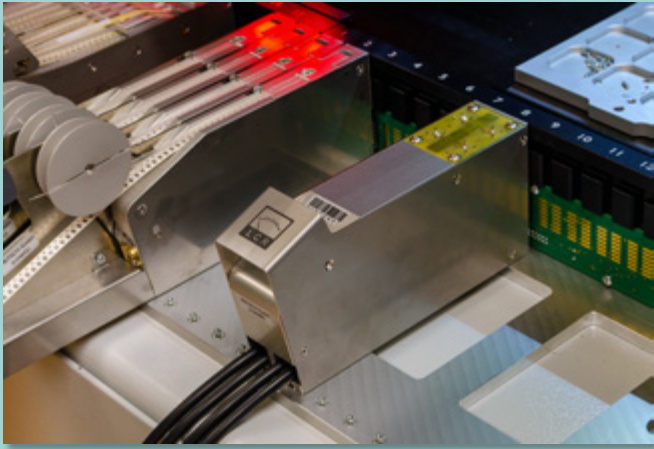

Test station for components

The need to document the exact value of a component is omnipresent. Whether it is a 100% control in the case of high grade mounting functions such as in the field of medicine and in the field of astronautics or also the tracing of a newly opened batch of components. The need to document the value of components is given. And a test station makes sense for particularly this purpose.

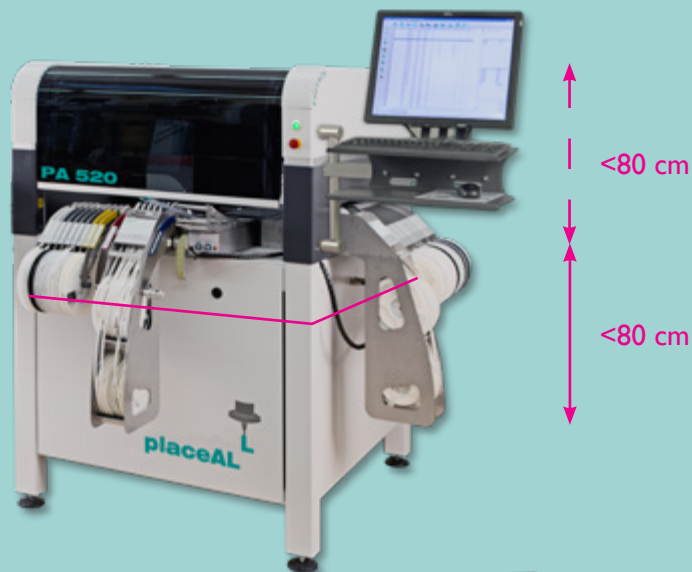

Dividable machine frame

To pass through door frames with less than 80 cm in width, the **placeALL**®520 and **placeALL**®620/620L machine frames can be built dividable, each part being smaller than 80 cm.

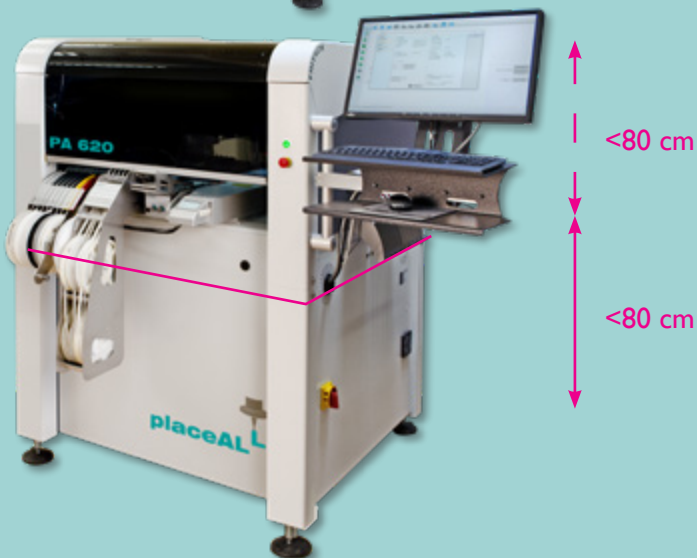

More machines

Stencil Printer

The increasing demands like finest structures and smallest components ask for new products. The solid construction of the FRITSCH stencil printers fulfill every requirement and the elaborate range enables the handling of structures up to 0,5 mm and oversized PCBs.



Manual pick & place systems

We have manual and semi-automatic manipulators in our product range for prototyping or small series. All process steps like dispensing of welding pastes / glue up to pick & place of components inclusive Fine Pitch can be performed. Depending on application the machines can be equipped with feeders for rolls and sticks.



Productionline

Any machines can be chained to reach a higher assembling performance and flexibility. The positions are divided according to demand.

Prototyping or a full-automatic productionline: depending on the customer request individual lines can be constructed.



Special solutions

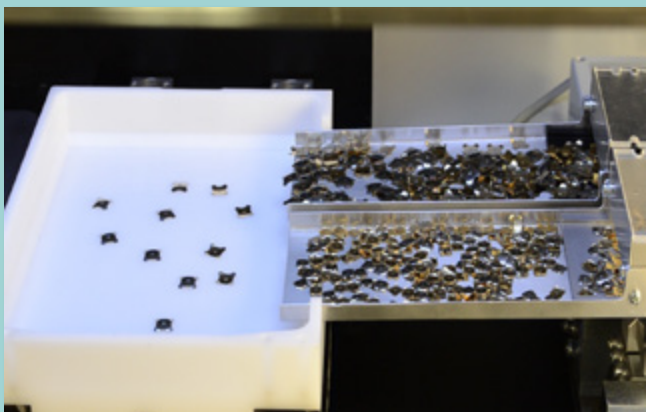
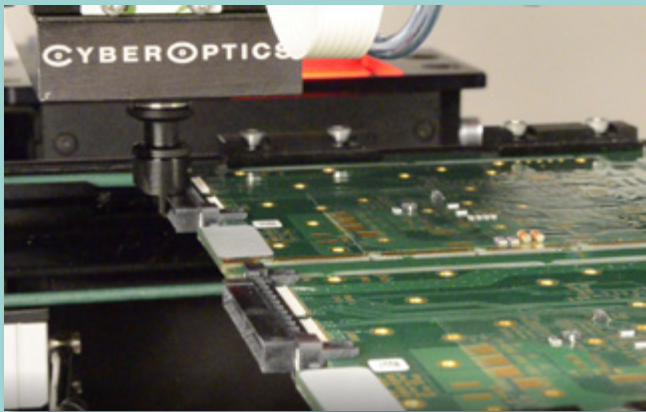
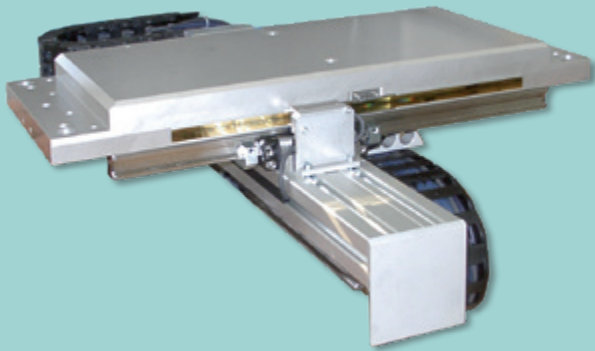

Customizations

Our flexible and standardized machines allow cost-effective adjustments to a wide range of tasks.

Integrable portal

The module consists of a portal with X,Y,Z and R axes with an integrated vacuum suction device for pick & place of the components. For the centering of components, a laser or vision centering can optionally be integrated directly on the Pick & Place head. There is also the option of integrating stationary vision systems for various detection and correction tasks.

Customized Feeder

Since we have the entire development, design and manufacture in-house, we also solve the tasks you have asked, for which the standard available feed units cannot be used. If you have any questions, simply contact our head office.

References

For more than 40 years we are specialized on all issues relating to Surface Mounting Technology. We realized with our customers several projects and their names guarantee our Know-how.



Hochschule für angewandte Wissenschaften Würzburg-Schweinfurt



BZM electronics

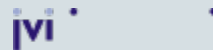
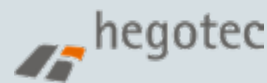

Ingenieurbüro V. Reuther



Fritsch GmbH

Kastnerstraße 8

D-92224 Amberg

Tel. +49 9621 78800-0

Fax +49 9621 78800-49

www.fritsch-smt.com

info@fritsch-smt.com